

Victor Products Ltd
New York Way
New York Industrial Park
Newcastle upon Tyne
NE27 0QF
ENGLAND
Tel : +44(0)191 2808000
Fax : +44(0)191 2808080



**Making Hazardous
Environments Work**

TYPE ML102 LED FACE LIGHT

EXPLOSION PROOF LUMINAIRE WITH FLAMEPROOF PROTECTION (TYPE d)

Certification number SIRA 09 ATEX 1328 I M2 Exd I Mb IP65

Certification number IECEx SIR 09.0134 I M2 Exd I Mb IP65

The certificate carries the group and category marking: - I M2

Where: I signifies suitability for use in mining and M2 signifies suitability for use in mines where it must be de-energised in the presence of an explosive atmosphere.

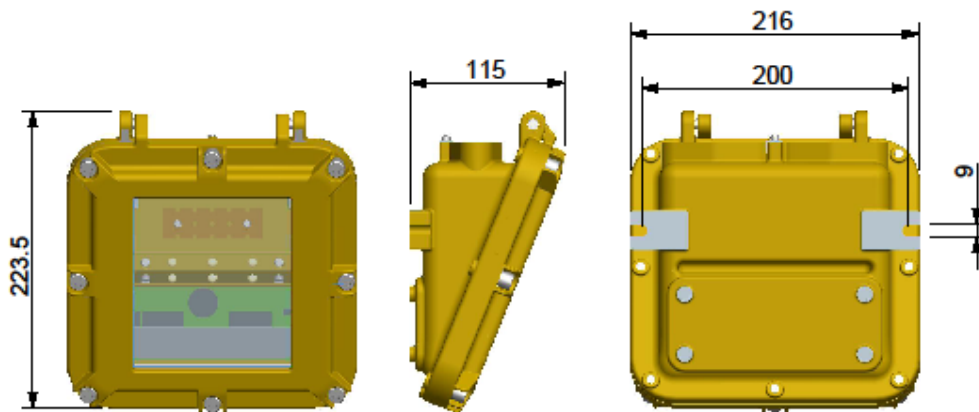

IMPORTANT

1. Read this leaflet carefully before commencing to install the luminaire and retain it for future reference.
2. Check the rating label to ensure that the luminaire is suitable for the supply provided.
3. The operating temperature range is -15°C to $+45^{\circ}\text{C}$.
4. The luminaire **MUST** be earthed.
5. Under **NO** circumstances should a luminaire be opened, even when isolated, when an explosive gas or dust environment is present.
6. **DO NOT LOOK DIRECTLY INTO LUMINAIRE.**

INSTALLATION

a) Mounting

The luminaire has mounting brackets as shown on the diagram above. The luminaire must be securely fastened in place. It can be mounted in any attitude. If magnets are to be used for mounting they can be supplied by Victor Products Limited.

b) Cable entries

Up to two cable entry holes for the accommodation of a suitable certified flameproof cable entry device/blanking plug (with or without the interposition of a suitable flameproof adaptor). The flameproof cable entry device/blanking plug/adaptor must be certified as Group I equipment under an EC-type certificate to directive 94/9/EC. The cable entry devices and cabling methods used in service must be suitable for their intended duty and the special types of cable used in mining. Access to the terminal block is made by removing all eight socket head cap screws on the front of the unit. The hinged lampglass assembly can then be opened. The terminal block is suitable for 6mm² cable. All terminal screws, used and unused should be fully tightened down.

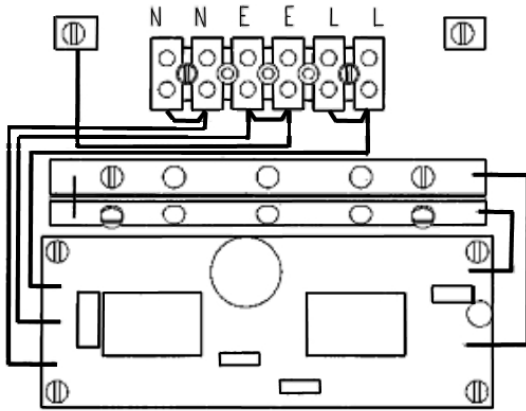

FITTING OR REPLACING LED STRIPS OR DAMAGED LAMPLGLASS ASSEMBLIES

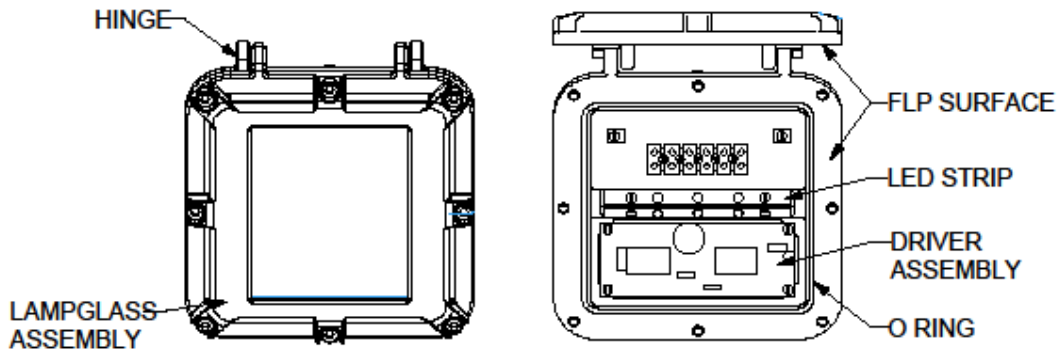

1. Remove all eight socket head cap screws from the front of the unit. The hinged lampglass assembly can then be opened.
2. The LED strips and/or driver assembly can be removed by disconnecting the cables from terminal block and from the push on terminals on the driver assembly. Remove the retaining screws.
3. Replace the LED strips and/or driver assembly. Fasten in place with the retaining screws and washers. Connect the cables to the terminal block ensuring all terminal screws are fully tightened down. Connect the cables from the LED strips to the push on terminals on the driver assembly ensuring correct polarity.
4. If the lampglass assembly is to be replaced, remove the hinge screws. Replacement is the reversal of this procedure.
5. Ensure O ring is fitted in place and apply a thin coating of a non-setting grease (silicone) to the FLP surfaces before closing the lampglass assembly.

6. Re-fit all eight socket head cap screws and washers. Fully tighten down all screws.

MAINTENANCE AND INSPECTION.

Frequency of inspection must be determined by the installer, but should be frequent enough to ensure that the luminaires continue to work in their designed manner. The more onerous the working conditions, the more frequent the inspection. The interval should never exceed two years.

The following list indicates some of the points that should be given particular attention. Suitable repairs should be carried out if required:-

- a) Clean all flameproof paths using a non-metallic or suitable non-corrosive cleaner and examine the flameproof paths for signs of damage. Replace damaged parts.
- b) Dirty lampglass should be cleaned.
- c) Replace cracked or damaged lampglass assemblies.
- d) Replace any missing fasteners with items of the correct type and quality.
- e) Fit new gaskets, lock-washers, etc as appropriate.
- f) Grease all flamepaths and screw threads with a non-setting grease (e.g. silicone)
- g) Ensure that blind tapped holes are clear of dirt, etc that could prevent correct closure of joints.
- h) Do not over-tighten fasteners on re-assembly.
- i) Ensure all mountings are secure and not corroded.
- j) Check cable glands for tightness and check the luminaire is efficiently earthed.
- k) Check resined joints for deterioration. If damaged then the assembly must be replaced in its entirety.
Resined components cannot be repaired except by the manufacturer.
- l) Any mechanically damaged parts must be replaced.
- m) A list of spares can be obtained from the manufacturer.

GENERAL

All components that are replaced should be in accordance with the manufacturer's specification. Failure to use approved parts invalidates the certification and approval of the luminaire and may make it dangerous.

NO modifications should be made to the luminaire without the knowledge and approval of the manufacturer.

HEALTH AND SAFETY AT WORK etc. ACT 1974

In the United Kingdom all equipment must be installed, operated and disposed of (as required) within the legislative requirements of the Health and Safety at Work etc. Act 1974. Leaflet No. HSS L1 refers to the Company's obligation and is available on request.

It is the responsibility of the user to select, install, operate and maintain the equipment in accordance with the relevant legislation and appropriate code of practice.



EU Only

WEE Producers Identification No. WEE/EA 0073UQ

Prices and design are subject to alteration without notice. All products are sold subject to our conditions of sale, copies of which are available on request.

We reserve the right to change characteristics of our products. All data is for guidance only

EC - Declaration of conformity

CE – Déclaration De Conformité
EG - Konformitätserklärung



Victor Products Ltd
New York Way
New York Industrial Park
Newcastle upon Tyne
NE27 0QF
ENGLAND

TYPE ML102 LED FACE LIGHT

Certification number **SIRA 09 ATEX 1328**
IECEX SIR 09.0134

Victor Products Ltd

Hereby declare our sole responsibility that the product which is the subject of this declaration is in conformity with the following standards or normative documents.

Erklären in alleiniger Verantwortung, daß das Product auf das sich diese Erklärung bezieht, mit der/den folgenden Norm(en) oder normativen Dokumenten Übereinstimmt.

Déclarons de notre seule responsabilité, que le produit auquel cette déclaration se rapporte, est conforme aux norme(s) ou aux documents normatifs suivants.

Number and date of standard Nr. Sowie Ausgabedatum der Norm No. Ainsi que date d'émission des normes.	Directive description Bestimmungen der Richtlinie Prescription de la directive
BS EN 60079-0 : 2006 BS EN 60079-1 : 2007	94/9 EC : Equipment and protective systems intended for use in potentially explosive atmospheres. 94/9 EG: Geräte und Schutzsysteme zur bestimmungsgemäßen Verwendung in explosionsgefährdeten Bereichen 94/9 CE: Appareils et systèmes de protection destinés a être utilisés en atmosphères explosibles.
EN50082 (1992) EN55015 (1993) EN 60555-2 (1987)	89/336 EEC: Electromagnetic Compatibility 89/336 EWG: Elektromagnetische Verträglichkeit 89/336 CEE: Compatibilité électromagnétique
Notified Body: SIRA Certification Services (0518) Rake Lane Eccleston Chester CH4 9JN	 H. Davis Engineering & Quality Manager November 2009
Notification No. SIRA 02 ATEX M191	