

Victor Products Ltd  
 New York Way  
 New York Industrial Park  
 Newcastle upon Tyne  
 NE27 0QF  
 ENGLAND  
 Tel : +44(0)191 2808000  
 Fax : +44(0)191 2808080



Making Hazardous  
 Environments Work

## TYPE 41LA MINING LUMINAIRE

EXPLOSION PROOF LUMINAIRE WITH FLAMEPROOF PROTECTION (TYPE d)

**Certification number SIRA02ATEX1407X I M2 EExd I**

The ATEX certificate carries the ATEX group and category marking: - I M2

Where: I signifies suitability for use in mining and M2 signifies suitability for use in mines where it must be de-energised in the presence of an explosive atmosphere.

<b>Victor</b>	Victor Products Ltd. Newcastle upon Tyne NE27 0 QF
TYPE 41LA FLUORESCENT LUMINAIRE. 240V 50Hz 58W T8 B1 PIN LAMP SIRA APPROVAL No. SIRA02ATEX1407X	
	I M2 EExd I M2 IP54 -15 C TO +50 C AMBIENT
DO NOT OPEN WHEN ENERGISED OR WHEN AN EXPLOSIVE GAS IS PRESENT.	
<b>CE</b> 0518	SERIAL No. STYLE No.

### TYPICAL LABEL

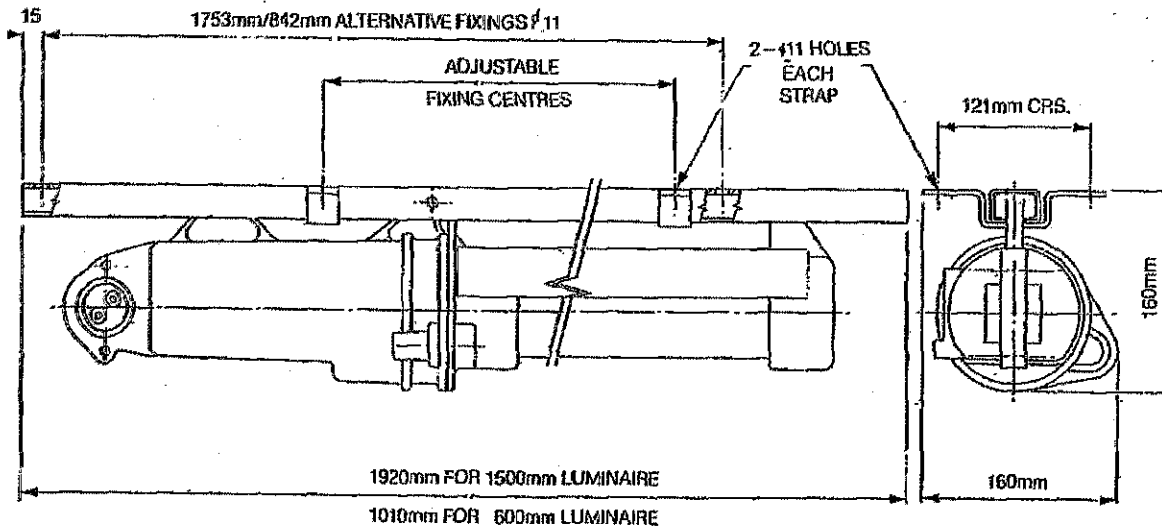

### IMPORTANT

1. Read this leaflet carefully before commencing to install the luminaire and retain it for future reference.
2. Check the rating label to ensure that the luminaire is suitable for the supply provided. Some luminaires have a dual voltage tapping on the internal Control Gear and this can be altered to suit the supply. Other luminaires are provided to run on specific voltages, i.e. 240v, 50Hz or 110/120v, 50Hz, etc. and these cannot be altered.
3. The operating temperature range is  $-15^{\circ}\text{C}$  to  $+50^{\circ}\text{C}$
4. The fluorescent lamp must be changed at the intervals recommended by the lamp manufacturer.
5. The luminaire **MUST** be earthed Under **NO** circumstances should a luminaire be opened, even when isolated, when an explosive gas or dust environment is present.

## **INSTALLATION**

### **a) Mounting**

The luminaire is supplied with mounting brackets as shown in the diagram on the front of this leaflet. The luminaire must be securely fastened to its supporting structure. Care must be taken not to put the luminaire under any distortion as this may over-stress the glass assembly or make it difficult to open during re-lamping.

### **b) Cable entries**

**Plug-in entries – 2 pin type** used on Type 41LA Roadway Luminaires will accept Plug or Cable Sealing Boxes accepted by HSE(M), for use with the interface to N.C.B. spec No. 691, see leaflet ML2. These entries can be blanked using Blanking Covers as shown on leaflet ML2.

## **FITTING OR REPLACING LAMPS**

1. The lampglass assembly is secured by a single bolt fixing and this is undone to remove the lampglass. The lampglass will be jacked out by the bolt, but if the assembly sticks jar the main body slightly to free it. Allow the lampglass assembly to hang on the suspension cord (Figs 1 & 2)
2. Undo the push-on terminals from the pins on the lamp support assembly Plate. Remove the lamp support assembly by turning the securing screw through a couple of turns and then rotate the assembly until the screw head clears the keyhole slot. Remove (See Figs 3 & 4)
3. To re-lamp, push the pin into the supporting clips. These clips should be located on the lampglass.
4. Push the terminations onto the remote end cap lamp pins.
5. Replace the lamp Assembly into the lampglass assembly and ensure that the locating bracket is passed over the head of the screw remaining in the lampglass assembly. Rotate to allow the keyhole slot to engage behind the screw head. Fully tighten the screw (Fig 5)
6. Push the remaining terminals onto their respective pins, taking care to ensure that they are fully engaged before re-closing the lampglass.
7. Grease the spigot and main fixing bolt with a non-setting grease such as silicone grease or Rocol ASP
8. Re-locate the lampglass Assembly in the Main Body Housing. Slide the lampglass forward until the fixing bolt makes contact with the thread in the fixing bolt hole in the main body. Do not attempt to force the spigot of the lampglass Assembly into the bore of the body. If at all tight, remove and re-enter to give the correct alignment.
9. Engage the thread of the fixing screw and tighten to close the lampglass assembly. The lampglass assembly is finally located when the lampglass assembly is fully home with the sealing ring compressed.
10. A feature of the 41LA is that the complete overtube assembly can be removed from the mounting channel by removing a split pin from the end of the channel and at the suspension cord point. The overtube may then be slid out of the mounting channel and replaced. See drawing on the front sheet for dimensions required for this.

## **MAINTENANCE AND INSPECTION.**

Frequency of inspection must be determined by the installer, but should be frequent enough to ensure that the luminaires continue to work in their designed manner. The more onerous the working conditions, the more frequent the inspection. The interval should never exceed two years.

The following list indicates some of the points that should be given particular attention. Suitable repairs should be carried out if required:-

- a) Clean all flameproof paths using a non-metallic scraper and / or suitable non-corrosive cleaners and examine the flameproof paths for signs of damage. Replace damaged parts.
- b) Dirty lampglasses should be cleaned using a mild soap solution.
- c) Replace cracked or damaged lampglasses.
- d) Replace any missing fasteners with items of the correct type and quality.
- e) Fit new gaskets, lock-washers, etc as appropriate.
- f) Grease all flamepaths and screw threads with a non-setting grease (e.g. silicone )
- g) Ensure that blind tapped holes are clear of dirt, etc that could prevent correct closure of joints.
- h) Do not over-tighten fasteners on re-assembly.
- i) Ensure all mountings are secure and not corroded, including the suspension cord.
- j) Faulty lamps should be changed.
- k) Check the paintwork and renovate as needed. Note: changes to surface finish, paint, etc. may affect the surface temperature classification
- l) Check cable glands for tightness and check the luminaire is efficiently earthed.
- m) Check the resin joints for deterioration. If damaged, the assembly must be replaced in its entirety. Resined components cannot be repaired except by the manufacturer.
- n) Any mechanically damaged parts must be replaced.

## BALLAST REPLACEMENT

To replace the ballast, first open the lampglass assembly to expose the terminations and the securing bracket. Remove the push-on terminals from the lamp end and also from the lamp support bracket. Disconnect the mains input leads to the ballast, turn the cheese-head screw securing the locking bracket until the bracket can be swiveled to allow the ballast to pass over it. In the case of a fixed ballast tray assembly, the securing screw must be removed prior to removing the ballast assembly. Replace the ballast and reverse the procedure taking care that connections are pushed fully home onto their respective pin connections and that no wires are trapped. Clean the bore of the main body to remove any corrosion, dirt, etc and lightly smear with a non-setting grease.

### GENERAL

All components that are replaced should be in accordance with the manufacturer's specification. Failure to use approved parts invalidates the certification and approval of the luminaire and may make it dangerous. NO modifications should be made to the luminaire without the knowledge and approval of the manufacturer

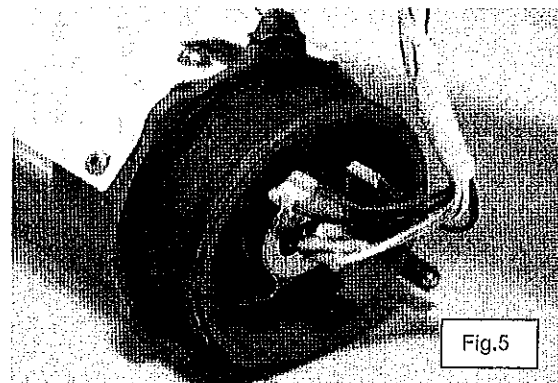
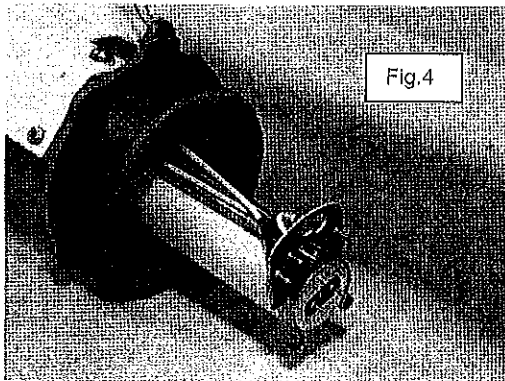
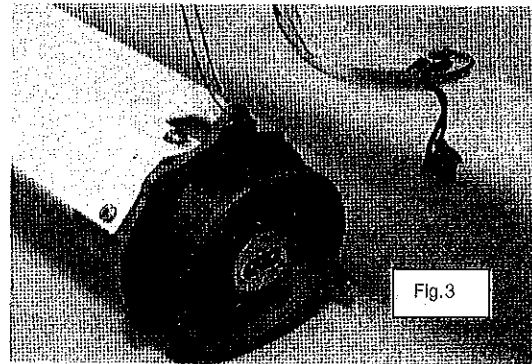
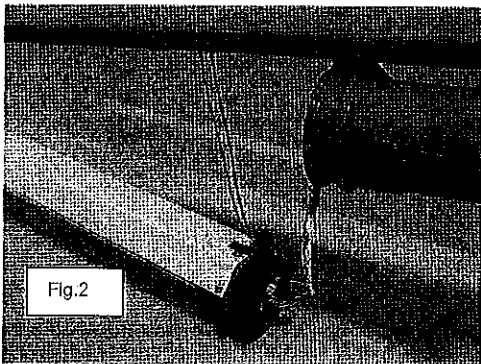
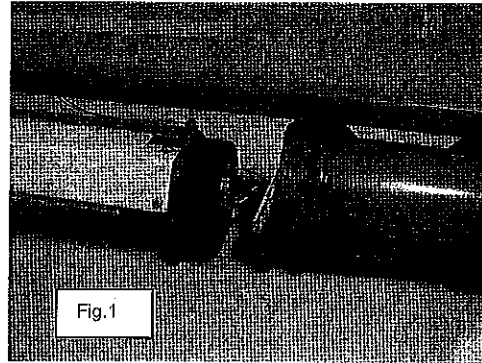

## HEALTH AND SAFETY AT WORK etc. ACT 1974

In the United Kingdom all equipment must be installed, operated and disposed of (as required) within the legislative requirements of the Health and Safety at Work etc. Act 1974. Leaflet No. HSS L1 refers to the Company's obligation and is available on request. It is the responsibility of the user to select, install, operate and maintain the equipment in accordance with the relevant legislation and appropriate code of practice.

Prices and design are subject to alteration without notice. All products are sold subject to our conditions of sale, copies of which are available on request. *We reserve the right to change characteristics of our products. All data is for guidance only*

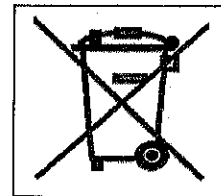

# EC - Declaration of conformity

CE - Déclaration De Conformité

EG - Konformitätserklärung



Victor Products Ltd  
New York Way  
New York Industrial Park  
Newcastle upon Tyne  
NE27 0QF  
ENGLAND

## TYPE 41LA MINING LUMINAIRE

Certification number SIRA02ATEX1407X I M2 EExd I

### Victor Products Ltd

Hereby declare our sole responsibility that the product which is the subject of this declaration is in conformity with the following standards or normative documents.

Erklären in alleiniger Verantwortung, daß das Product auf das sich diese Erklärung bezieht, mit der/den folgenden Norm(en) oder normativen Dokumenten Übereinstimmt.

Déclarons de notre seule responsabilité, que le produit auquel cette déclaration se rapporte, est conforme aux norme(s) ou aux documents normatifs suivants.

<b>Number and date of standard</b> Nr. Sowie Ausgabedatum der Norm No. Ainsi que date d'emission des normes.	<b>Directive description</b> Bestimmungen der Richtlinie Prescription de la directive
<p>EN 50014 (1998) EN 50018 (2000)</p> <p>This equipment has been reviewed against the requirements of EN60079-0: 2006 and EN60079-1: 2004, in respect of the differences from the standards to which this certificate was issued; none of these differences affect this equipment.</p> <p>Diese Ausrüstung ist gegen die Anforderungen von EN60079-0 wiederholt worden: 2006 und EN60079-1: 2004, in Bezug auf die Unterschiede von den Standards, zu denen diese Bescheinigung ausgestellt wurde; keine dieser Unterschiede beeinflussen diese Ausrüstung.</p> <p>Cet équipement a été passé en revue contre les conditions d'EN60079-0 : 2006 et EN60079-1 : 2004, en ce qui concerne les différences des normes auxquelles ce certificat a été délivré ; aucune de ces différences n'affecte cet équipement.</p>	<p><b>94/9 EC : Equipment and protective systems intended for use in potentially explosive atmospheres.</b></p> <p>94/9 EG: Geräte und Schutzsysteme zur bestimmungsgemäßen Verwendung in explosionsgefährdeten Bereichen</p> <p>94/9 CE: Appareils et systèmes de protection destinés à être utilisés en atmosphères explosibles.</p>
<p>EN50082 (1992) EN55015 (1993) EN 60555-2 (1987)</p>	<p><b>89/336 EEC: Electromagnetic Compatability</b></p> <p>89/336 EWG: Elektromagnetische Verträglichkeit</p> <p>89/336 CEE: Compatibilité électromagnétique</p>
<p><b>Notified Body:</b> SIRA Certification Services (0518) Rake Lane Eccleston Chester CH4 9JN</p>	<p> H. Davis Engineering &amp; Quality Manager Mar 2007</p>
Notification No. SIRA 02 ATEX M191	